

DS-1691ZJ-X

Pendant Mount

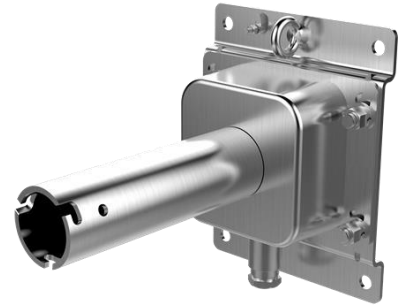

Feature

- SUS304 stainless steel
- Applicable to explosion-proof speed dome (PTZ camera)

Dimension

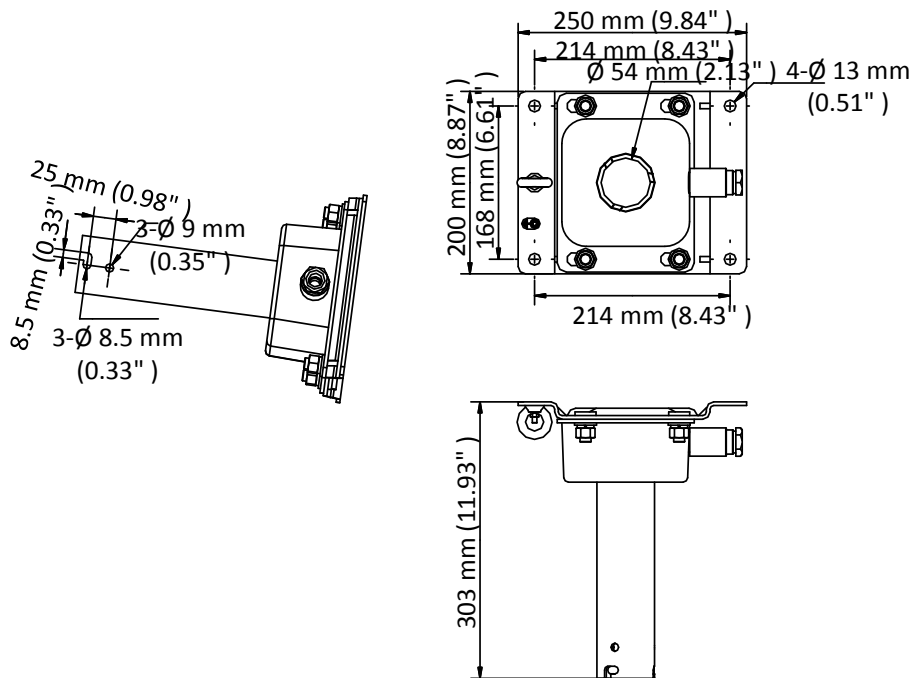

Available Model

DS-1691ZJ-X

Parameter

Model	DS-1691ZJ-X
Parameters	Pendant Mount
Appearance	Natural Stainless Steel Color
Material	SUS304
Dimension	250 mm × 200 mm × 303 mm (9.84" × 8.87" × 11.93")
Weight	6 kg (13.23 lb.)

Note

- The mount should be installed on the flat ceiling.
- The waterproof rubber is necessary for the outdoor application.
- The wall must be capable of supporting at least 8 times as much as the total weight of the camera, and the mount.
- The mount's maximum load capacity is 30 kg (66 lb.).