

TR-WE45-A-IN-BLACK PTZ Dome Wall Mount



Specifications

Bracket	TR-WE45-A-IN
Application	Indoor or outdoor, wall installation for PTZ dome camera
Dimensions(L × W × H)	216mmx141mmx313mm(8.5" x 5.6"x 12.3")
Weight	1.0kg(2.2lb)
Material	Aluminum alloy

Dimensions

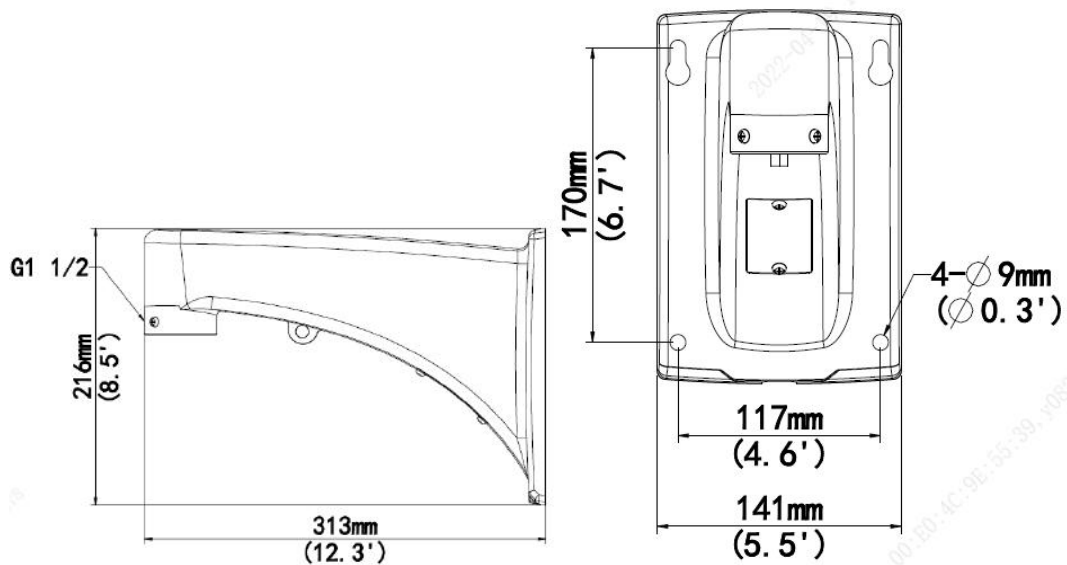

Zhejiang Uniview Technologies Co.,Ltd.

South Tower, Building 10, Wanlun Science Park, 88 Jiangling Road, Hangzhou, P.R.China 310051

Email: overseasbusiness@uniview.com; globalsupport@uniview.com

<http://www.uniview.com>

©2022 Zhejiang Uniview Technologies Co.,Ltd. All rights reserved.

*Product specifications and availability are subject to change without notice.