



SX-2000

Audio Management System

The EN 54 logo is a square with an orange triangle in the top-left corner and the text 'EN 54' in white on a dark background.

EN 54



EN 54 Standard-compliant and network-enabled for extended multi-location installations with centralized control, the SX-2000 Series achieves performance without compromise.

Ideal for creating ultra-reliable large scale PA and VA systems

Introducing a scalable new system for configuring versatile and highly effective PA applications. The SX-2000 Series is in compliance with the EN 54 Standard, and features new matrixing capabilities, so a single system can have its components distributed in different locations, yet under centralized control. Ideal for large-scale installations ranging over multiple buildings as well as local systems, the versatile SX-2000 Series is particularly well-suited for airports and railway stations, factories, shopping malls and large offices. Versatility is ensured by such features as a dual power source and redundant backups for fail-safe operation, making it a cost-effective solution for virtually any installation, and without long lead times or the expense of a custom system. A fireman's microphone feature is also included, for enhanced effectiveness in an emergency. SX-2000 Series components enable creation of an ideal system for all sorts of application requirements.

- EN 54 Standard-compliant system
- Integrated public address and voice alarm
- Digital surveillance
- Decentralized system capability
- DSP for clear announcements & enjoyable BGM
- Four different simultaneous emergency messages



EN 54 is a standard of the European Union (EU) for fire alarm systems, ensuring high product quality and reliability, and enabling better integration of Voice Alarm (VA) and Public Address (PA). EN 54 plays a significant role in the market for voice evacuation equipment, as the member states of the European Union replace their local standards with the EN 54 standard. All emergency voice evacuation systems marketed in the member states of the European Union are required to be certified to this standard.

The SX-2000 system is certified on the European Norm EN 54-16 with **CPD number 1134-CPD-102**.

The VX-2000DS (ER/UK version) Power manager and VX-200PS (ER/UK version) power supply are certified on the European Norm EN 54-4 with **CPD number 1134-CPD-083**.

SX-2000 System Configuration

The SX-2000 system is comprised of the units presented below. The SX-2000SM, SX-2100AI and SX-2100AO/2000AO can create a minimum system with 8 audio inputs/8 audio outputs. The system is expandable to maximum 64 audio inputs/256 audio outputs and 1,416 control inputs/1,416 control outputs.

SX-2000SM System Manager

SX-2100AI Audio Input Unit

SX-2100AO Audio Output Unit

SX-2000AO Audio Output Unit

SX-2000CI Control Input Unit

SX-2000CO Control Output Unit

RM-200SF Fireman's Microphone

RM-200SA Remote Microphone

RM-210 Remote Microphone Extension



**RM-200SF
Fireman's Microphone**

EN 54
16



**RM-200SA Remote Microphone
RM-210 Remote Microphone Extension**

EN 54
16



SX-2000SM System Manager

EN 54
16



SX-2100AI Audio Input Unit

EN 54
16



SX-2100AO Audio Output Unit

EN 54
16



SX-2000AO Audio Output Unit

EN 54
16



SX-2000CI Control Input Unit

EN 54
16

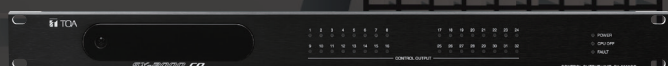

SX-2000CO Control Output Unit

EN 54
16

SX-2000 Series



Convenient system component distribution to different locations through a network

- Uses commercially available switching hub (certain specifications are required).
- Uses commercially available cables.
 - CAT-5 (100 Base-TX).
 - Optical fiber (100 Base-FX).

Full digital signal processing for improved performance

- Digital signal processing allows public announcements with high fidelity 48 kHz sampling frequency and 24-bit PCM AD/DA conversion.
- Available audio inputs/outputs.
 - Inputs: 64
 - Outputs: 256
 - Each audio output has signal processing functions including 6-band filters, COMP and Delay.
- Maximum 16 ch simultaneous broadcasting channels.
- Available control 1,416 inputs and 1,416 outputs.

Multipurpose remote control

- Makes it easy to configure broadcast zones independently or by groups and allows BGM programming as desired. Automatic Mic-Off function prevents inappropriate microphone use when inadvertently left on.
- The RM-200SF/200SA/210 can display the malfunctions or failure signals in the SX-2000 system.



Failsafe operation

- Fully operable on DC power
- Power failure measures
- Redundant dual power supply
- Additional analog backup
- Fully redundant dual network

Failure detection and emergency broadcasting

- Malfunctions or failures in the SX-2000 system are detected within 100 seconds, generating an alert on the display and a sound signal. At the same time, a failure log is created and can be stored on PC by TCP/IP. The system also constantly checks and measures speaker impedance values to prevent potential overloads or wiring errors.



- A Fireman's Microphone function allows the system to be used for emergency broadcasts.
- Each SX-2100AO can connect one standby amplifier.
- Failures of External equipment connected the SX-2000 Series units are also detected.



Quick maintenance

- Parameter settings storable on CF cards.
- Current parameter settings are instantly restored if the unit has to be replaced.
- Network connectivity simplifies wiring requirements (fewer cables required) and speeds up connections.

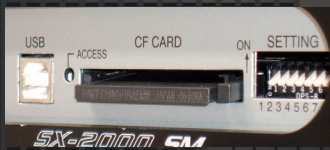

Future expandability

- Easy expansion simply by adding more units.
- Easy connectivity with minimal wiring requirements.

Reduced power consumption

- Power consumption reduced and increased efficiency in power supply.

Compact and space saving

- Multi-channel amplifier zone installation for dedicated amplifier/channel usage.
- System configuration suited for use in multiple zones.
- Smaller dimensions.

Software setting

- Parameter settings including fade-in/fade-outs for various input sources, priority level assignment of multiple input sources, and operation logs can be conveniently stored in a CF card.

SX-2000 Series

Distributed Control System Example (University)

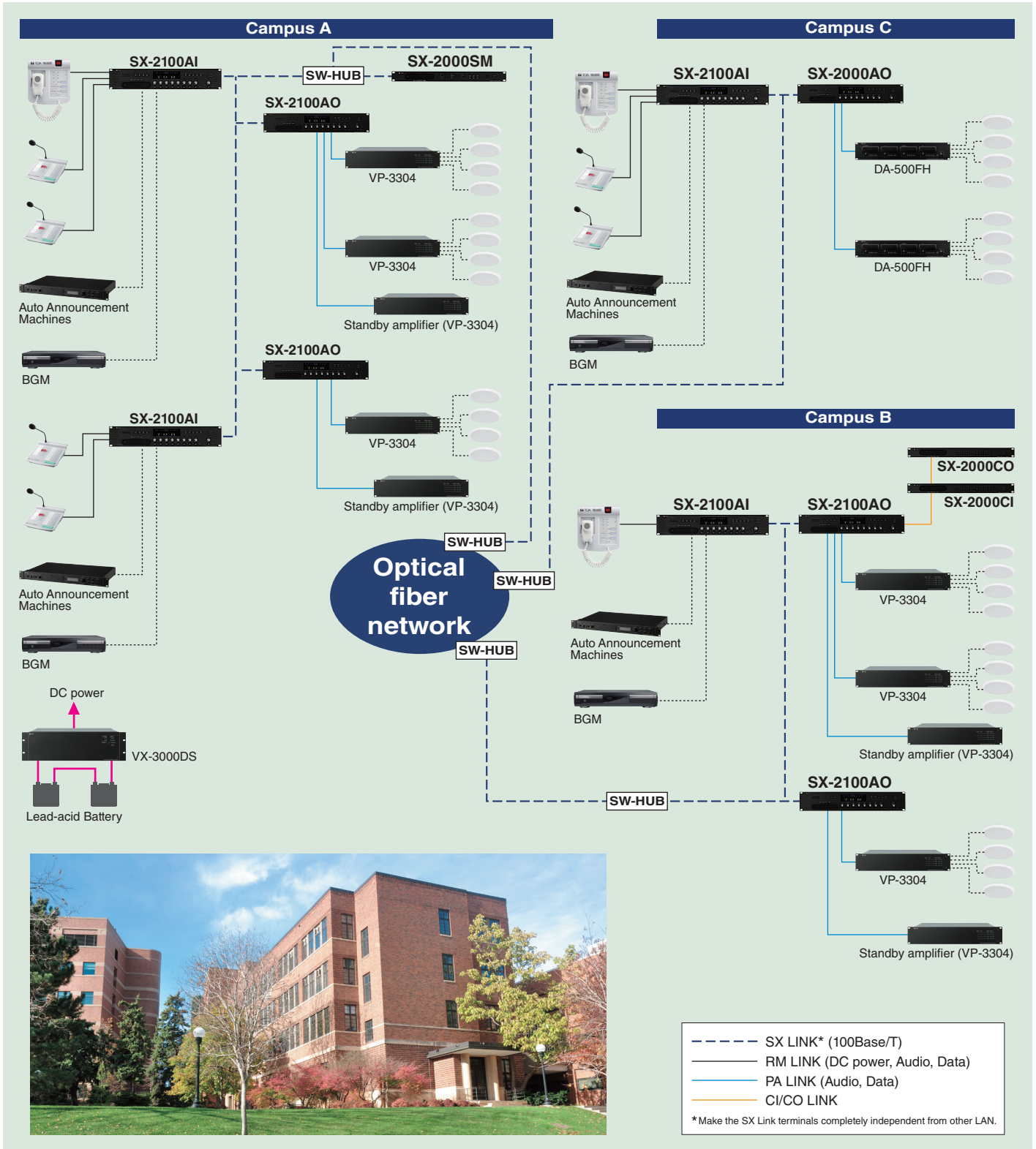
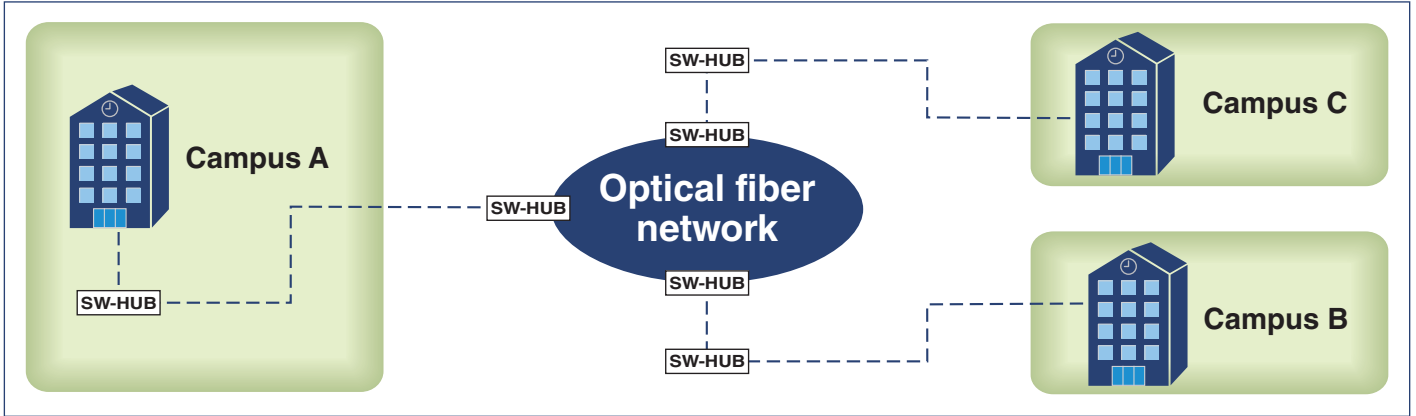

Integration of SX-2000 with N-8000 IP Intercom strengthens system capabilities.

A large system with up to 2048 zones is realized on the IP Network.
 From a remote location, IP Station* can make a paging call to any selected zone(s).
 *N-8610RM and N-8600MS.

Example: Distributed Factory Application

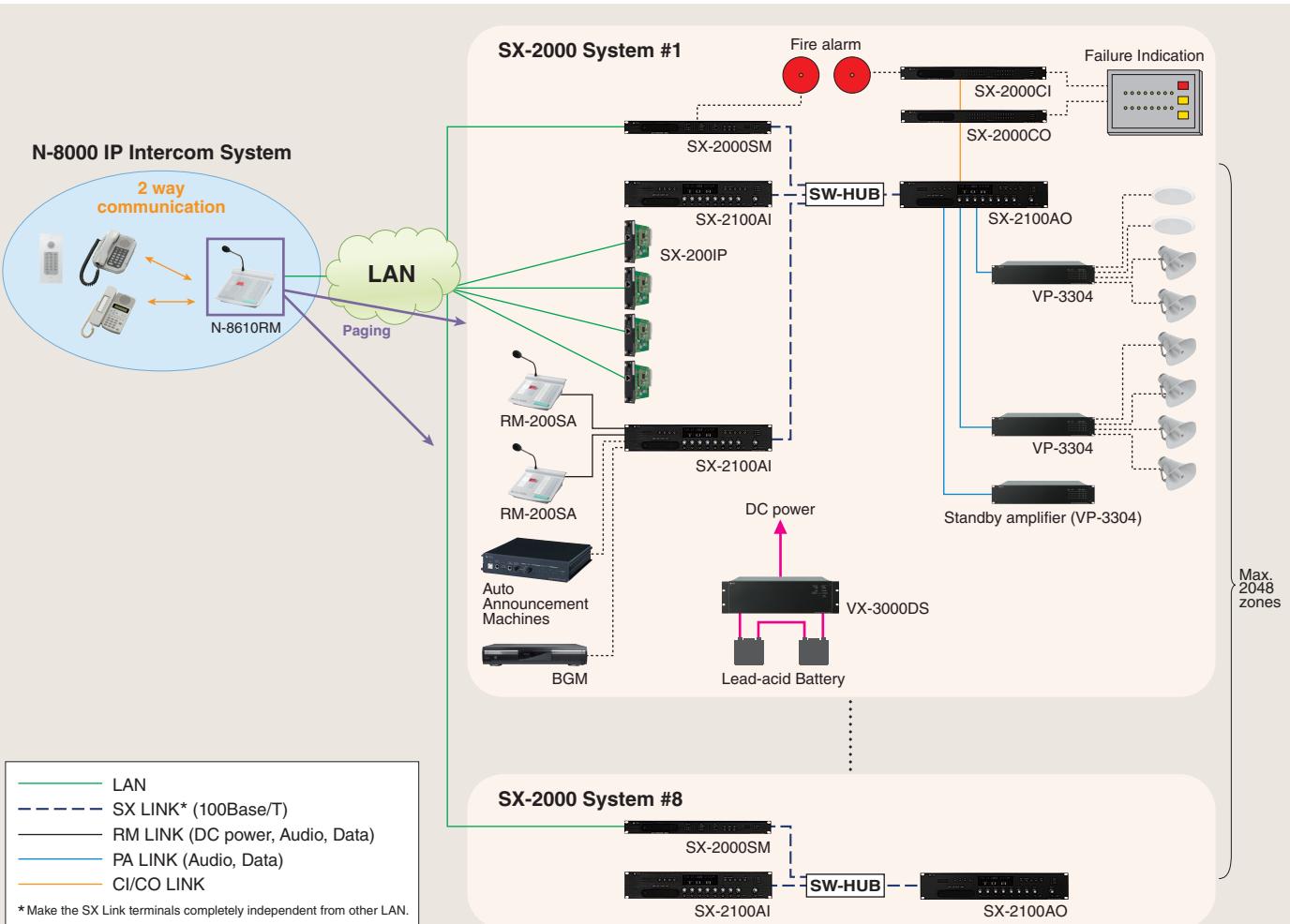
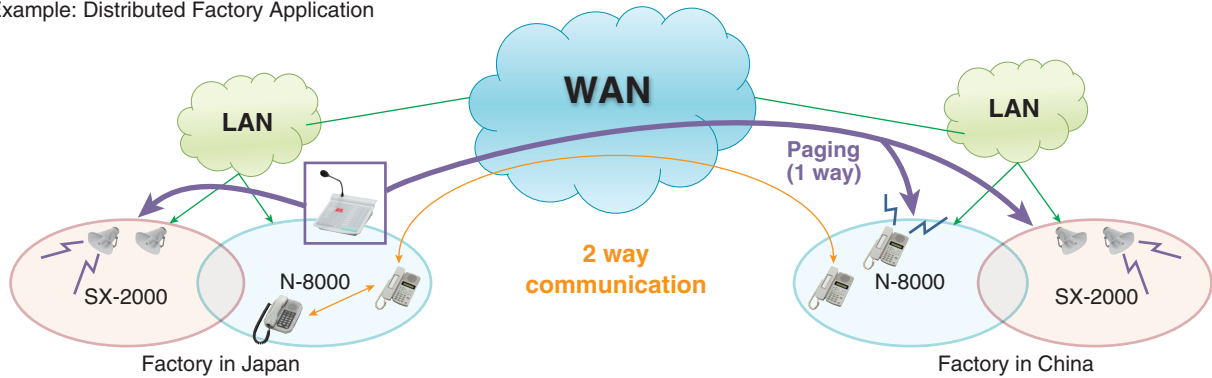

SPECIFICATIONS



Model No.		SX-2000SM System Manager
Power Source		24V DC, 2 power inputs construction enables dual- redundant power supply.
Current Consumption		Under 0.8A (when operated on 24V DC)
SX Link	Network I/F Matrix System Specification	2 x 100BASE-TX circuits, RJ45 connector Bus: 16 Audio input: Max. 64 ch, Audio output: Max. 256 zones Contact input: Max. 1416, Contact output: Max. 1416 Priority control: 512 steps Event log: Max. 1,000 events x 32 files Failure log: Max. 100 events x 32 files
	Matrix System Configuration (Maximum connectable units)	SX-2000AI/2100AI: Max. 8 units, SX-2000AO/2100AO: Max. 32 units, SX-2000CI: Max. 32 units, SX-2000CO: Max. 32 units, RM-200SA: Max. 64 units (up to 8 RM-200SA per SX-2100AI)
LAN	Connection Cable/Device	Shielded Category 5 twisted pair cable (CAT5-STP)**
	Network I/F	1 x 10 BASE-T/100 BASE-TX circuit, RJ45 connector for maintenance use
	Network Protocol	TCP/IP
Analog Link	Connection Cable	Shielded Category 5 twisted pair cable for LAN (CAT5-STP)
	Input/Output Connector	Output: 2, RJ45 connector
DS Link	Connection Cable	Shielded Category 5 twisted pair cable (CAT5-STP)
	Usable Unit	VX-2000DS
Failure Data Input	Connector/Cable	2 interface, RJ45 connector, Shielded Category 5 twisted pair cable (CAT5-STP)
Failure Data Output		3 inputs (ACK/RESET/LAMP TEST)
Control Input		4 outputs (CPU FAULT/GENERAL FAULT/CPU OFF/BUZZER)
Surveillance Section for The Control Input Lines		8 inputs
Control Output		Connection resistance to make the function inactive: 20k 5% Connection resistance to make the function active: 10k 5% Connector cable: Twisted pair cable (shielded type is recommended) Maximum cable distance: 10m
24V DC Output	Maximum Feeding Current	8 outputs
Memory Card	Output Voltage	100mA
		24V DC 10% or less
	Insertion slot: 1 (supplied CF card (128MB))	

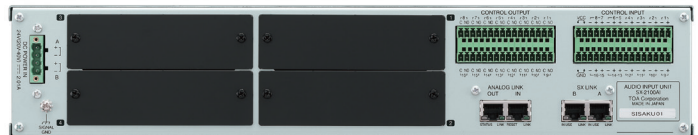

Model No.		SX-2100AI Audio Input Unit
Power Source		24V DC, 2 power inputs construction enables dual- redundant power supply.
Current Consumption		Under 1.5A (when operated on 24V DC)
Audio Input		8 inputs, module construction (max. 4 modules)
Control Input		16 inputs
Control Output		16 outputs
Audio Input Characteristic		Sampling frequency: 48kHz
SX Link	Network I/F	2 x 100BASE-TX circuits, RJ45 connector
	Connection Cable/Device	Shielded Category 5 twisted pair cable (CAT5-STP).**
Analog Link	Input/Output Connector	Input: 1 input, RJ45 connector Output: 1 output, RJ45 connector
	Connection Cable	Shielded Category 5 twisted pair cable (CAT5-STP)

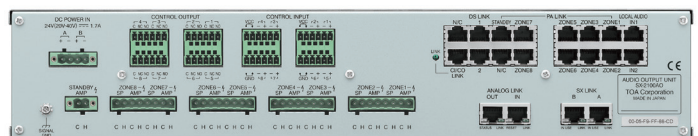

Model No.		SX-2100AO Audio Output Unit
Power Source		24V DC, 2 power inputs construction enables dual- redundant power supply.
Current Consumption		Under 1.2A (when operated on 24V DC)
PA Link	Audio Output	8 outputs and standby AMP, 0dB*, suitable load: 600 or above, electronically-balanced, RJ45 connector
	Audio Output Characteristic	Frequency response: 20 – 20kHz Sampling frequency: 48kHz D/A converter: 24 bit
	Connection Cable	Shielded Category 5 twisted pair cable (CAT5-STP)
Local Audio Input	Audio Input	2 inputs, 0dB*, 10k, electronically-balanced, RJ45 connector
	Audio Input Characteristic	Frequency response: 20 – 20kHz Sampling frequency: 48kHz D/A converter: 24 bit
	Control Input	2 inputs
SX Link	Connection Cable	Shielded Category 5 twisted pair cable (CAT5-STP)
	Network I/F	2 x 100 BASE-TX circuits, RJ45 connector
Analog Link	Connection Cable	Shielded Category 5 twisted pair cable (CAT5-STP)**
	Input/Output Connector	Input: 1 input, RJ45 connector/Output: 1 output, RJ45 connector
DS Link	Connection Cable	Shielded Category 5 twisted pair cable (CAT5-STP)
	Usable Unit	VX-2000DS
CI/CO Link	Connector/Cable	2 interface, RJ45 connector, Shielded Category 5 twisted pair cable (CAT5-STP)
	Usable Unit	SX-2000CI or SX-2000CO
Speaker Line Failure Detection Section	Connector/Cable	1 interface, RJ45 connector, Shielded Category 5 twisted pair cable (CAT5-STP)
	Connection Cable	Removable terminal block, SP/AMP: 8 pins, STANDBY AMP: 2 pins, AWG 24 – AWG 16
	Maximum Input	100Vrms, 5Arms
	Fault Detection System Method	Short circuit, open circuit, ground fault Impedance or End of line
Control Input	End of Line	In case of normal: Terminated by 470k between the speaker line and the shielded In case of open: Opened between the speaker line and the shield
	Impedance	Minimum load: 2k (5W) at 100V line
Control Output		8 inputs
		8 outputs

*1 0dB = 1V

** 0dB = 0.775V

** This network must be made completely independent from other LAN.

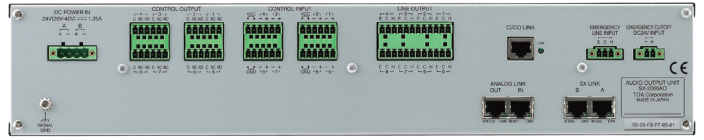

Model No.		SX-2000AO Audio Output Unit
Power Source		24V DC, 2 power inputs construction enables dual- redundant power supply.
Current Consumption		Under 0.79A (when operated on 24V DC)
Audio Output		8 outputs, 0dB ⁺¹ , suitable load: 600 or above, electronically-balanced output changeable into transformer-balanced output (optional)
Audio Output Characteristic		Frequency response: 20 – 20kHz Sampling frequency: 48kHz D/A converter: 24 bit
Emergency Line Input		Emergency signals switched and sent to Input 1 (H, C, E) by relay
Emergency-Cutoff 24V Input		1 input, input current: under 5mA
SX Link	Network I/F	2 × 100 BASE-TX circuits, RJ45 connector
	Connection Cable/Device	Shielded Category 5 twisted pair cable (CAT5-STP) ^{*3}
Analog Link	Input/Output Connector	Input: 1 input, RJ45 connector/Output: 1 output, RJ45 connector
	Connection Cable	Shielded Category 5 twisted pair cable (CAT5-STP)
CI/CO Link	Usable Unit	SX-2000CI or SX-2000CO
	Connection Cable	1 interface, RJ45 connector, Shielded Category 5 twisted pair cable (CAT5-STP)
Control Input		8 inputs
Control Output		8 outputs

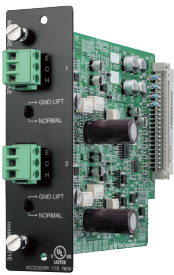

Model No.	D-921E Mic/Line Input Module (24 bits Monaural Type)
Input	2 channels, Mic/Line changeable Mic: -50/-36dB ⁺² , 4.7k, electronically-balanced Line: -10/+4dB ⁺² , 10k, electronically-balanced 12V Phantom power supply Ground lift switch
Connector	Removable Terminal Block connector
A/D Converter	24 bit
Sampling Frequency	48kHz
Frequency Response	20 – 20kHz, 1 dB
Dynamic Range	Over 100 dB
Total Harmonic Distortion	Under 0.05%

Model No.	D-921F Mic/Line Input Module (24 bits Monaural Type)
Input	2 channels, Mic/Line changeable Mic: -50/-36dB ⁺² , 4.7k, electronically-balanced Line: -10/+4dB ⁺² , 10k, electronically-balanced 12V Phantom power supply Ground lift switch
Connector	XLR connector
A/D Converter	24 bit
Sampling Frequency	48kHz
Frequency Response	20 – 20kHz, 1 dB
Dynamic Range	Over 100 dB
Total Harmonic Distortion	Under 0.05%

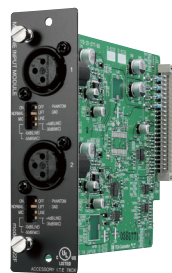
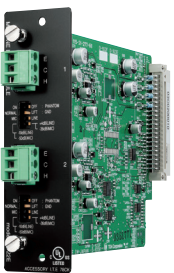

Model No.	D-922E Mic/Line Input Module (20 bits Monaural Type)
Input	2 channels, -50/-36/-10/+4dB ⁺² , 4.7k, electronically-balanced 12V Phantom power supply Ground lift switch
Connector	Removable Terminal Block connector
A/D Converter	20 bit
Sampling Frequency	48kHz
Frequency Response	20 – 20kHz, 1 dB
Dynamic Range	Over 85 dB
Total Harmonic Distortion	Under 0.2%

Model No.	D-922F Mic/Line Input Module (20 bits Monaural Type)
Input	2 channels, -50/-36/-10/+4dB ⁺² , 4.7k, electronically-balanced 12V Phantom power supply Ground lift switch
Connector	XLR connector
A/D Converter	20 bit
Sampling Frequency	48kHz
Frequency Response	20 – 20kHz, 1 dB
Dynamic Range	Over 85 dB
Total Harmonic Distortion	Under 0.2%

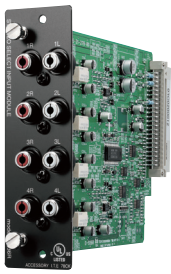

Model No.	D-936R Stereo Select Input Module
Input	Monaural x 2, 10 dB ^{*2} , 10k , RCA pin jack
A/D Converter	24 bit
Sampling Frequency	48kHz
Frequency Response	20 – 20kHz, 1 dB
Dynamic Range	Over 100 dB
Total Harmonic Distortion	Under 0.05%

Model No.	SX-200RM Remote Microphone Interface Module
Audio Input	2 inputs, 0dB ^{*1} , RJ45 connector
Audio Input Characteristic	Sampling frequency: 48kHz A/D converter: 24bit
Level Control	Audio input (0 to +12dB)



Model No.	SX-2000CI Control Input Unit	
Power Source	24V DC (operational range: 20V – 40V DC)	
Current Consumption	0.7A or less (maximum value in the power operating range) 0.55A or less (when operated on 24V DC)	
Control Input	32 inputs, no-voltage make contact input, open voltage: 24V DC, short-circuit current: 2mA, photo coupler input, removable terminal block (16 pins)	
Surveillance Section for The Control Input Lines	Connection resistance to make the function inactive: 20k 5% Connection resistance to make the function active: 10k 5% Connector cable: Twisted pair cable (shielded type is recommended) Maximum cable distance: 10m (32.81 ft)	
CI/CO Link	Input/Output Connector	Input: 1 input, Output: 1 output RJ45 connector
	Connection Cable	Shielded Category 5 twisted pair cable (CAT5-STP) (1 pair of data wire + 1 pair of control wire)
24V DC Output	Output Voltage	24V DC 10% or less
	Maximum Feeding Current	100mA
	Connector	Removable terminal block (2 pins)

When operating in stand-alone mode with SX-2000CO		
Priority Control		No priority control, Terminal number-based priority, Last-in-first-out priority and First-in-first-out priority
Connection Cable	Main cable	Shielded CPEV cable* or STP Category 5 straight cable * When connecting the power supply to each unit: 1 pair for data line When connecting the power supply only to the SX-2000CI: 1 pair data line and 2 pairs power line for a redundant power supply system, or 1 pair data line and 1 pair power line for a non-redundant power supply system
	Branch cable	STP Category 5 straight cable (with RJ45 connectors)
Maximum Cable Distance		800m
Maximum Delay Time		300ms



Model No.	SX-2000CO Control Output Unit	
Power Source	24V DC, 2 power inputs construction enables dual- redundant power supply.	
Current Consumption	Under 0.29A (when operated on 24V DC)	
Control Input	32 outputs	
CI/CO Link	Input/Output Connector	Input: 1 input, Output: 1 output RJ45 connector
	Connection Cable	Shielded Category 5 twisted pair cable (CAT5-STP)

When operating in stand-alone mode with SX-2000CI		
Connection Cable	Main cable	Shielded CPEV cable* or STP Category 5 straight cable * When connecting the power supply to each unit: 1 pair for data line When connecting the power supply only to the SX-2000CI: 1 pair data line and 2 pairs power line for a redundant power supply system, or 1 pair data line and 1 pair power line for a non-redundant power supply system
	Branch cable	STP Category 5 straight cable (with RJ45 connectors)
Maximum Cable Distance		800m
Maximum Delay Time		300ms

*1 0dB = 1V

*2 0dB = 0.775V



Model No.	RM-200SA Remote Microphone
Power Source	24V DC (supplied from the SX-2100AI audio input unit) or DC input power supply connector (when the optional AD-246 power supply unit used)
Current Consumption	Under 240mA
Audio Output	0dB*, 600Ω, balanced
External Microphone Input	-40dB*, 2.2kΩ, unbalanced, mini jack
Distortion	Under 1%
Frequency Response	100 – 20kHz
S/N Ratio	Under 60dB
Microphone	Unidirectional electret condenser microphone with AGC (ON/OFF selectable)
Chime	Built inside, monitoring possible using built-in speaker
Level Control	Microphone sensitivity control, Monitor speaker volume control, Chime (adjustable using the software)
Connection Cable	Main line: Shielded CPEV cable or Shielded Category 5 twisted pair cable (CAT5-STP) Branch line: Shielded Category 5 twisted pair cable (CAT5-STP)
No. of Connectable Expansion	Max. 4 units
Monitor Speaker	Built inside
Indicator	Power indicator, Failure indicator, Function switch indicator, Covered switch indicator, Broadcast switch indicator
Dimensions	190 (W) × 76.5 (H) × 215 (D)mm (excluding microphone)



Model No.	RM-210 Remote Microphone Extension
Current Consumption	20mA max. (in terms of RM-200SF/200SA's DC power input)
Connection	Connection by way of dedicated cable
Number of Function Keys	10
Dimensions	110 (W) × 76.5 (H) × 215 (D)mm



Model No.	SX-200IP IP Interface Module
Network Section	Network I/F: 10BASE-T/100BASE-TX (Automatic-Negotiation) Network Protocol: TCP/IP, UDP, HTTP, RTP, ARP, ICMP, IGMP Voice packet loss recovery: Silence insertion Audio delay time: 80 ms, 320 ms (controllable on the software)
Indicator	Operation indicator (RUN)



Model No.	RM-200SF Fireman's Microphone
Power Source	24V DC (supplied from the SX-2100AI audio input unit)
Current Consumption	Under 240mA
Audio Output	0dB*, transformer-balanced
Distortion	Under 1%
Frequency Response	200 – 15kHz
S/N Ratio	Over 55dB
Microphone	Unidirectional dynamic microphone with talk key, AGC (ON/OFF selectable), microphone element failure detectable by using a built-in small oscillator
Connection Cable	Shielded CPEV cable or Shielded Category 5 twisted pair cable (CAT5-STP)
No. of Connectable Expansion	Max. 5 units
Monitor Speaker	Built inside
Operation	Emergency key, Function keys, CPU switch, Reset switch
Indicator	Status indicators, Power indicator, Failure indicator, CPU indicator, Selection indicators, Microphone indicator, Broadcast status indicator
Dimensions	200 (W) × 215 (H) × 95 (D)mm



Model No.	RM-200RJ Terminal Unit
Applied Voltage	Under 40V
Withstand Voltage	1A
Voltage Indicator	Monitor terminals: Terminal No 7 (+) and terminal No 8 (-), extinguish voltage: 14V or less, lighting voltage: 21V or more, indicator ON/OFF switchable
Connector	RJ45 connector: 1
Terminal	M3 screw terminal (10 pins), distance between barriers: 6.62mm
Dimensions	84 (W) × 116 (H) × 25.7 (D)mm



Model No.	N-8610RM IP Remote Microphone Station
Power Source	Power supply device that complies with IEEE802.3af standard or 12 V DC (use of the optional AC adapter)
Speech Method	Hands-free conversation (use of goose neck microphone)
Audio Frequency Range	300 Hz - 7 kHz
Microphone	Unidirectional electret condenser microphone
Built-in Speaker	6.6 cm (2.6") cone-type rated output 0.3 W, 8 Ω
Network Section	Network I/F: 10BASE-T/100BASE-TX (Automatic-Negotiation) Network Protocol: TCP/IP, UDP, HTTP, RTP, ARP, ICMP, IGMP Audio Packet transmission system: Unicast, Multicast Number of paging destinations: Unicast (max. 16), Multicast (max. 191) Voice packet loss recovery: Silence insertion Audio delay time: 80 ms, 320 ms (controllable on the software)
No. of Connectable Expansion	Max. 4 units (maximum 2 unit of PoE power supply)
Indicator	Power indicator, Status indicator, Selection indicator, Broadcast status indicator, Microphone indicator
Dimensions	190 (W) × 76.5 (H) × 215 (D) mm (excluding microphone)

SYSTEM EQUIPMENT



VP-3504
VP-3304
VP-3154

Digital Power Amplifier

The digital amplifier is more compact, lightweight and energy efficient. Each channel has an independent power source for enhanced reliability, and BGM input ports support local BGM broadcasting.

Power Source	31V DC (operating 20-34V DC)	
Amplification System	Class D	
Current Consumption	VP-3504	20A (Rated Output Power)
	VP-3304	11A (Rated Output Power)
	VP-3154	6A (Rated Output Power)
Rated Output Power	VP-3504	500W × 4 (at 100V line) 350W × 4 (at 70V line) 250W × 4 (at 50V line)
	VP-3304	300W × 4 (at 100V line) 210W × 4 (at 70V line) 150W × 4 (at 50V line)
	VP-3154	150W × 4 (at 100V line) 105W × 4 (at 70V line) 75W × 4 (at 50V line)
Input	PA LINK: 4 channels BGM: 4 channels (volume adjustment: 4 channels)	
Frequency Response	40Hz – 16kHz; ±3dB	
Distortion	1% or less	
S/N Ratio	80dB or more	
Dimensions	482 (W) × 88.4 (H) × 390 (D)mm	
Weight	VP-3504	7.7kg
	VP-3304/3154	7.3kg



VP-2064 (60 W × 4)
VP-2122 (120 W × 2)
VP-2241 (240 W × 1)
VP-2421 (420W × 1)

Power Amplifier

Power Amplifier requires the VP-200VX Power Amplifier Input Module per channel.

Power Source	28V DC
Current Consumption (at 1/8 rated output)	VP-2064/VP-2122: 4.8A in total, VP-2241: 4.8A, VP-2421: 7.6A
Impedance	VP-2064: 167Ω (100V), 83Ω (70V), 41Ω (50V) VP-2122: 83Ω (100V), 41Ω (70V), 21Ω (50V) VP-2241: 41Ω (100V), 21Ω (70V), 10Ω (50V) VP-2421: 24Ω (100V), 12Ω (70V), 6Ω (50V)
Rated Output	VP-2064: 60W × 4, VP-2122: 120W × 2, VP-2241: 240W × 1, VP-2421: 420W × 1
Number of Module Slot	VP-2064: 4, VP-2122: 2, VP-2241/VP-2421: 1
Frequency Response	40 – 16kHz
Distortion	Under 1% or less
S/N Ratio	80dB or more



VX-2000DS Emergency Power Supply

The VX-2000DS Emergency Power Supply Unit supplies the DC power to each equipment in the SX-2000 system by connecting the VX-200PS Power Supply Unit.

Power Source	AC mains, 50/60Hz
Power Consumption	240W max.
Charging Method	Trickle charging
Charging Current	5A max.
Charging Output Voltage	27.3V± 0.3V
Power Supply Input	6
DC Power Output	6



VX-3000DS Power Supply Manager

The VX-3000DS Power Supply Manager supplies DC power to all SX-2000 system components. It combines two built-in power source units with a high-performance charger. If the primary power supply is cut off, the VX-3000DS switches automatically to auxiliary battery power.

Power Source	220-230V AC, 50/60Hz
DC Power Output (AC mode) (at 1/8 rated output, 1kHz)	Rated output: 2300W (31V, 72.5A, total DC power output) Peak output: 2780W (29V, 96A, total DC power output)
Charging Method	Temperature compensated Trickle charging
Charging Output Voltage	27.3V ±0.3V
Dimensions	482 (W) × 132.6 (H) × 400 (D)mm
Weight	11.8kg

VX-200PS Power Supply Unit

The VX-200PS Power Supply Unit is mounted in the VX-2000PF Power Supply Frame when in use.



Power Source	AC mains, 50/60Hz
Power Consumption	580W
PS OUT	Rated output: 210W (29V, 7.25A) × 2 Peak output: 400W × 2



VX-2000PF Power Supply Frame

Up to 3 VX-200PS units can be installed in the unit.



DA-250FH/500FH Multichannel Power Amplifier

The DA-250FH/500FH are 4-Channel Digital Amplifiers designed for 100V line high-impedance distribution and features lightweight, compact, high power output, and high efficiency.

Power Source	AC mains, 50/60Hz
Power Consumption (at 1/8 rated output, 1kHz)	DA-250FH: 230W, 1.6A DA-500FH: 399W, 2.6A
Amplification System	Class D
Rated Output	DA-250FH: 250W × 4 (100V, 40Ω) DA-500FH: 500W × 4 (100V, 40Ω)
Input	4 circuits, +4dB*, 10k
Frequency Response	50 – 20kHz
Distortion	0.1% (1kHz)
S/N Ratio	100dB

* 0dB = 0.775V