

Exd Optical Beam Smoke Detector

User Guide

EN

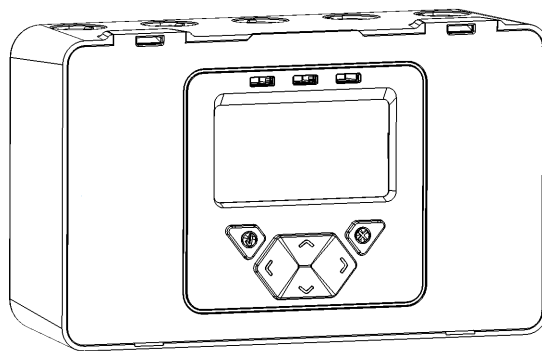

1. Description

This Ex d Optical Beam Smoke Detector is used for fire detection in explosive atmospheres.

It consists of a standard Controller, combined with rugged flameproof / dustproof Transmitter and Receiver heads. The Transmitter and Receiver heads are designed to be mounted within the protected hazardous area, whilst the Controller is housed outside it.

Once installed, the Transmitter head projects a modulated infra-red beam (inherently safe optical radiation) across the protected area, to the Receiver head mounted opposite. The received signal strength is monitored and analysed in the Receiver, and should the signal strength fall below the preset threshold for more than the fire delay selected by the user, a fire alarm is signalled to the Controller.

2. Statement of Intended Use

This system is intended for use as a Smoke Detector only, in Exd IIC/IIIC, or lower grade areas. It must not be used in areas with a greater hazard rating. It must be installed and tested by approved, competent personnel, in accordance with all regulatory and local codes of practise. No liability shall be accepted for installations not conforming to this requirement.

The equipment is covered by certificate number Sira 15ATEX1260, and the following instructions apply.

1. The equipment may be used with flammable gases and vapours with apparatus group II and with temperature class T6 in the ambient temperature range -20°C to +55°C.
2. The equipment is only certified for use in ambient temperatures in the range -20°C to +55°C and should not be used outside this range.
3. Installation should be carried out by suitably trained personnel in accordance with the applicable code of practice.
4. Inspection of this equipment shall be carried out by suitably trained personnel in accordance with the applicable code of practice.
5. The equipment does not have any user-serviceable parts and must be returned to the manufacturer for servicing or repair.
6. This Installation Guide contains the system Principle of Operation; system Specification; Installation Precautions; Installation Setting Up and Testing; Installation diagrams.
7. The certification of this equipment relies upon EMH29 Enclosure Component (typically Aluminium Alloy) Certificate No. TRAC13ATEX0058U from JCE (Europe) Ltd.
8. If the equipment is likely to come into contact with aggressive substances, then it is the responsibility of the user to take suitable precautions that prevent it from being adversely affected, thus ensuring that the type of protection provided by the equipment is not compromised.

Aggressive substances: e.g. acidic liquids or gases that may attack metals, or solvents that may affect polymeric materials.

Suitable precautions: e.g. regular checks as part of routine inspections, or establishing from the material's data sheets that it is resistant to specific chemicals.

9. Label details:

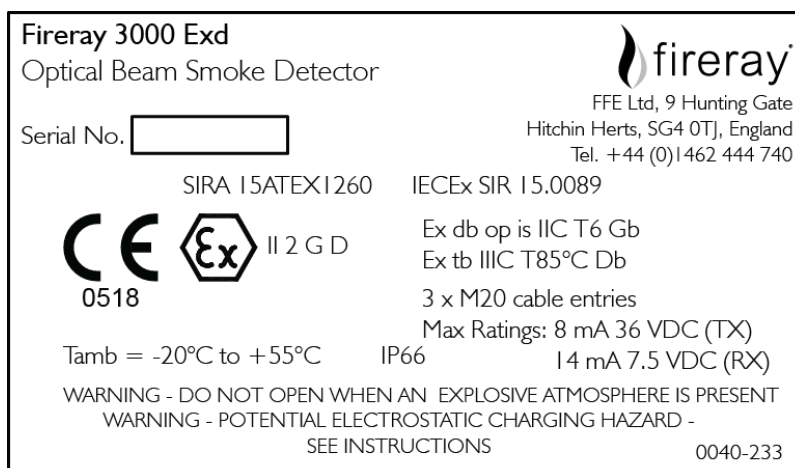

WARNING

The area into which the parts are to be fitted must be made safe before attempting any work on the system. It must also be checked thoroughly prior/during/after commissioning, to ensure it cannot compromise the safety of the area in which it is fitted. Note that only the transmitter and receiver parts may be installed in the hazardous area, NOT the controller unit.

If the flamepath of the enclosure is damaged in any way, the unit must be returned to the manufacturer and a new unit purchased.

3. General Information

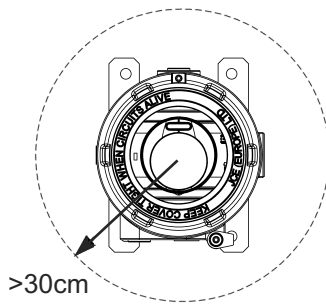

Ensure clear line of sight from Receiver to Transmitter

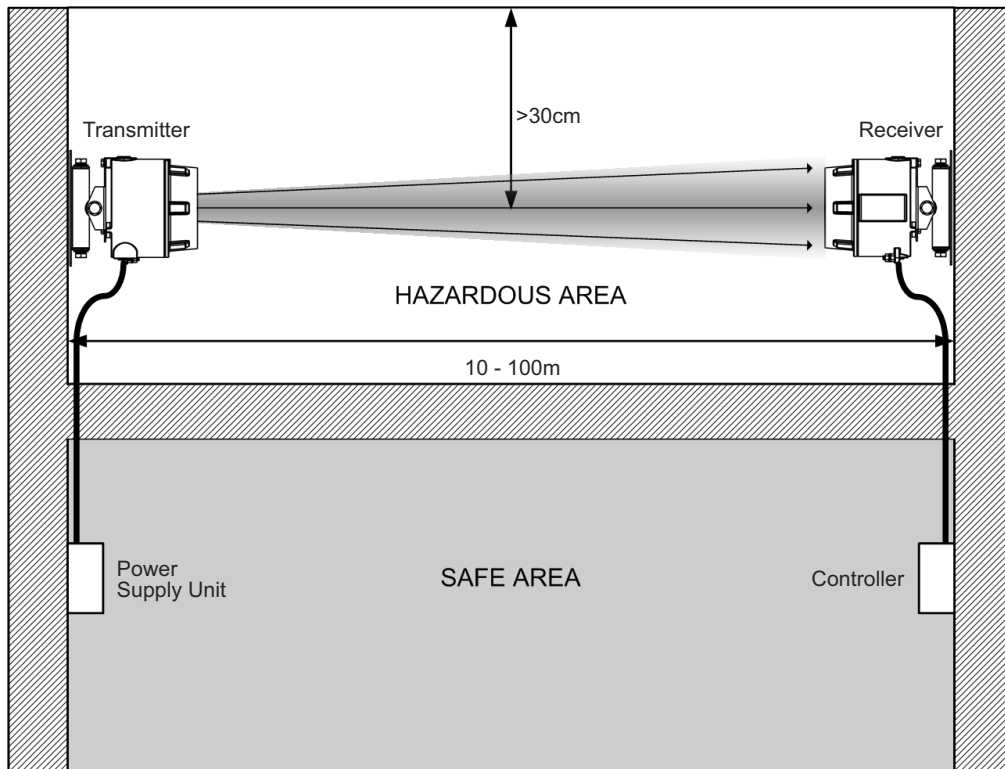

- **IMPORTANT NOTE: The infrared beam path MUST be kept clear of obstructions at all times! Failure to comply may result in the system initiating a Fire or Fault signal.**
- All installations should comply with local regulations
- For installations approved to UL 268 refer to NFPA 72 for installation guidance. In such installations, it is advised that the maximum distance of Transmitter and Receiver from the ceiling must be 10% of the distance between floor and ceiling
- Ensure a clear line of sight from Receiver to Transmitter
- Mount on solid surfaces (structural wall or girder) and ensure fixing is rigid
- Position beam as high as possible, but with a minimum distance of 30cm from Receiver/Transmitter to ceiling
- Mount Receiver and Transmitter directly opposite each other
- Do NOT position where personnel or objects can enter the beam path
- Do NOT install the Transmitter or Receiver in environments where condensation or icing are likely to occur

4. Wiring Diagrams

Wiring two Receivers onto two zones:

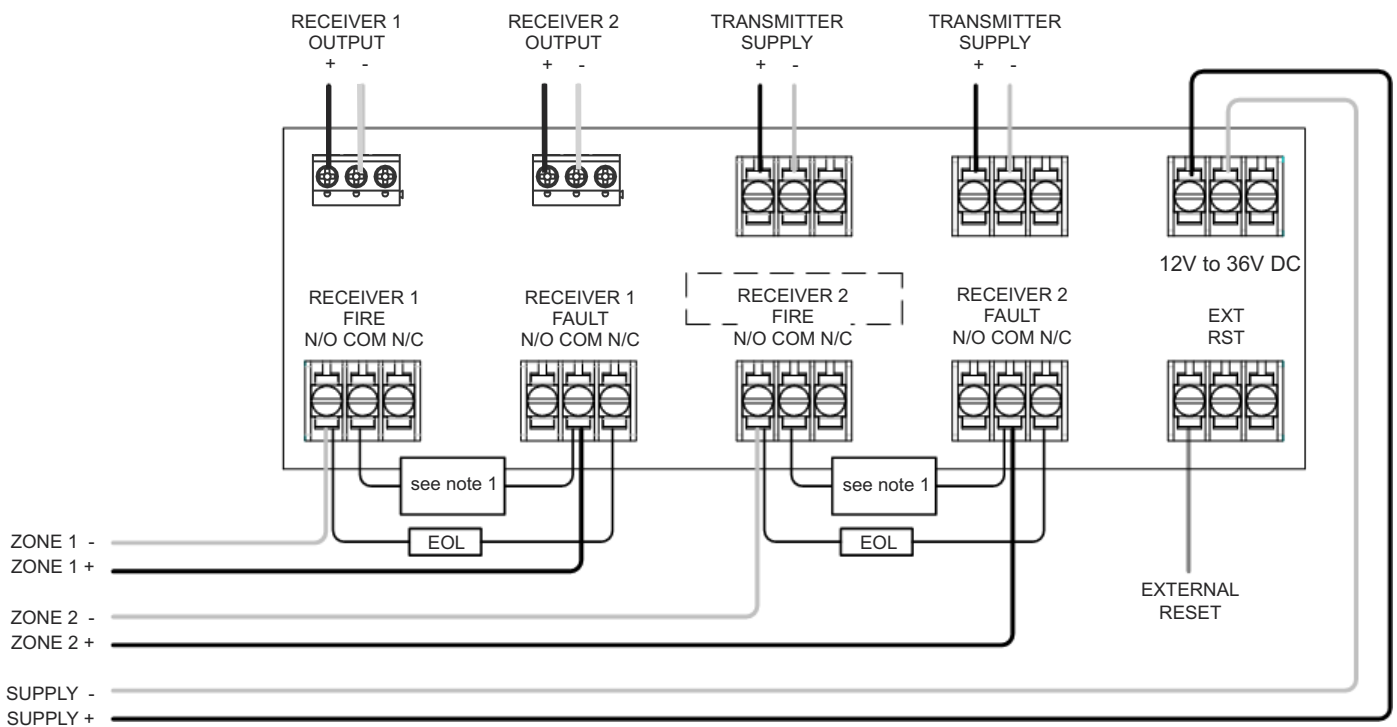

For connection of two Receivers to one zone:

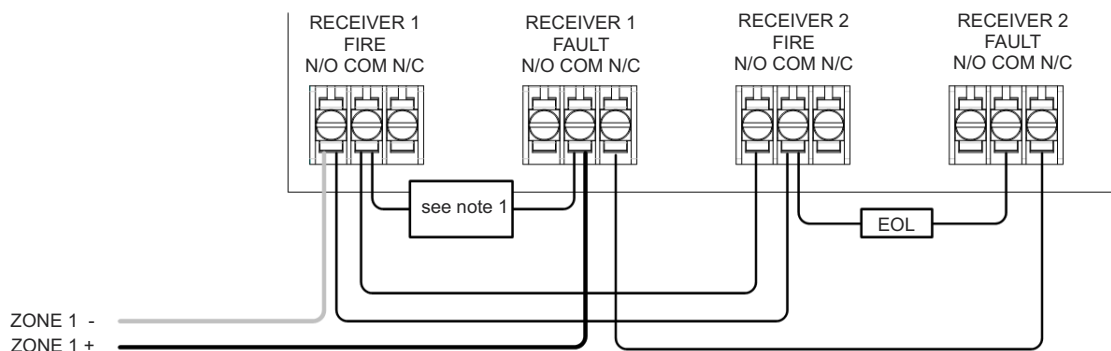

- Note 1: This component is the fire resistor. Its value is specified by the Fire Control Panel manufacturer. For U.S. installations it is typically a short circuit
- ALWAYS use a separate 2-core cable for each Receiver head
- CAUTION: For system monitoring - Do not use looped wire under any terminals. Break wire run to provide monitoring of connections
- Components not supplied:
 - End Of Line ('EOL') component - supplied by Fire Control Panel manufacturer
 - Fire Resistor
- After installation, check operation of Fire and Fault connection on Fire Panel
- Apply a voltage of 5V to 40V to 'EXT RST' contact for at least 2 seconds to clear a latched fire condition
- For wiring to other types of Fire Control Panel, or to wire multiple Controllers onto one Zone, refer to additional installation instructions supplied with the product

5. Fitting the Product

Step 1

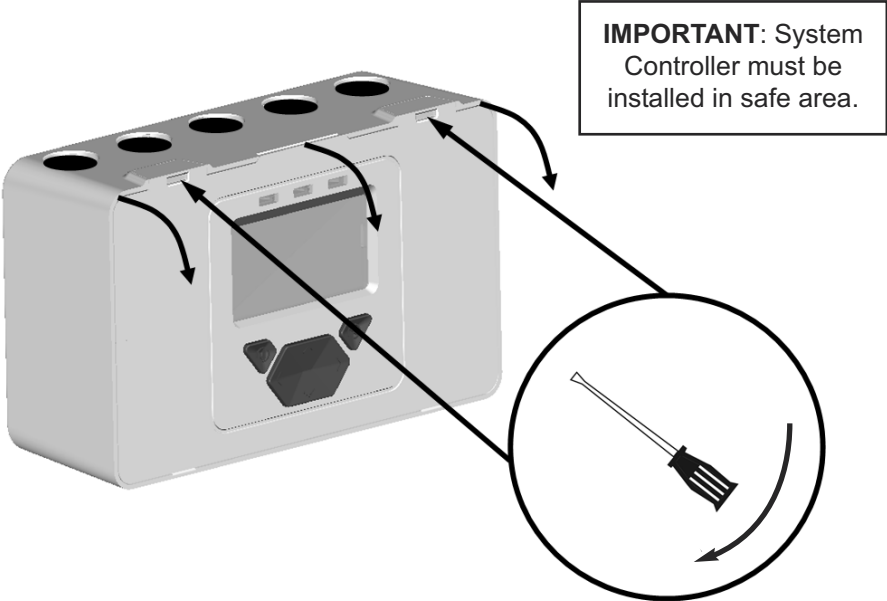

Step 2: Attach bracket

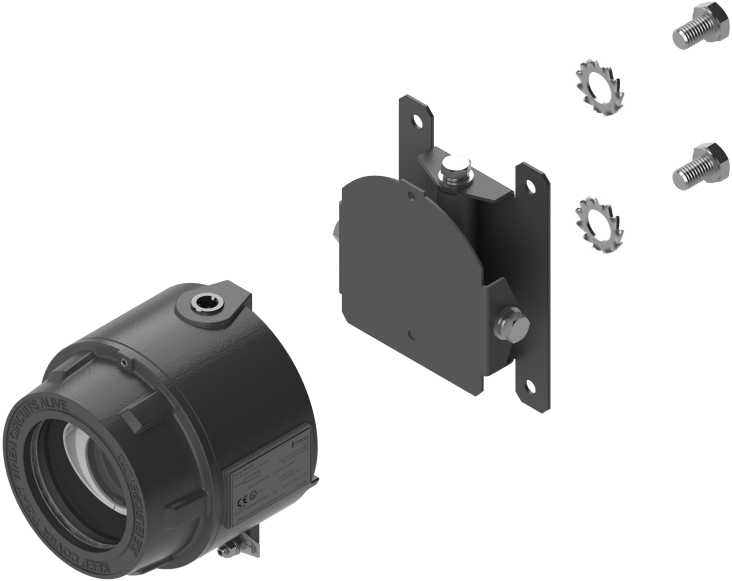

Step 3: Mount to solid surface



Step 4: Wiring

RECEIVER:

IMPORTANT: The cable gland **MUST** be ATEX certified to:

II 2GD
Ex db IIC Gb
Ex tb IIIC Db
IP66

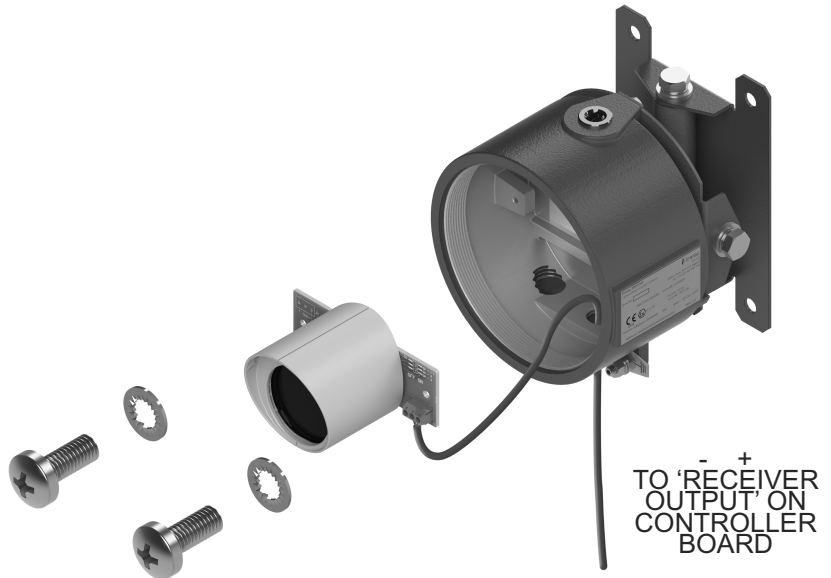

TRANSMITTER:

IMPORTANT: select correct DIL switch setting for distance

SWITCH			Distance in Metres
SW - 1	SW - 2	SW - 3	
OFF	OFF	OFF	75 - 100
OFF	OFF	ON	50 - 75
OFF	ON	ON	25 - 50
ON	ON	ON	10 - 25

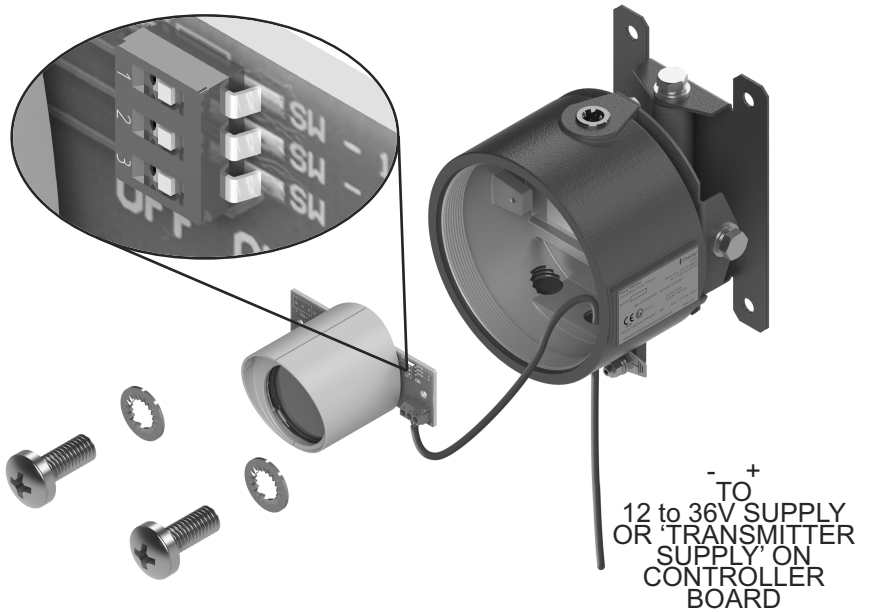

Step 5: Secure covers

3mm Hex Key (supplied)

IMPORTANT: secure covers on Transmitter and Receiver using the locking screw **BEFORE** applying power

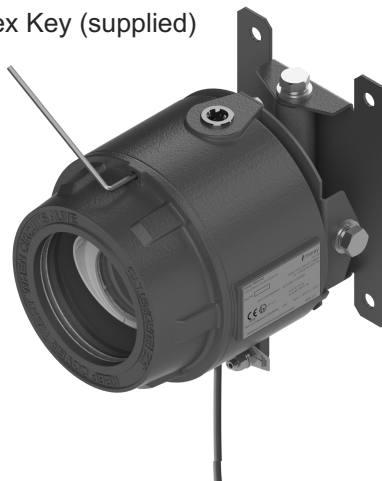

6. Apply Power

NOTE: One System Controller can be used to control and monitor up to two Receiver heads. The '#' symbol in this guide is used to represent the number of the Receiver currently selected (1 or 2).

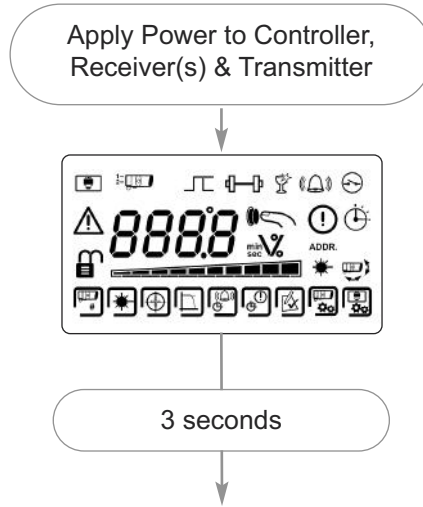

- Receivers are not found (normal at this stage):

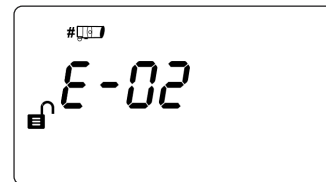

- Commissioned System:

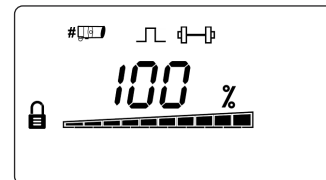

- Receivers have been found but not commissioned:

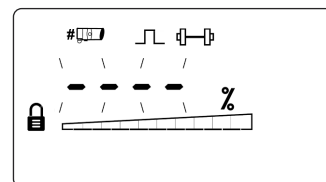

- Communications fault, or no Receiver connected:

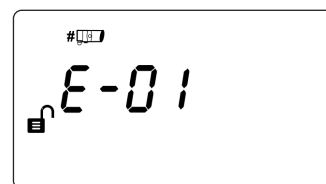

7. Enter Pass Code to Access Engineering Menu

Press **✓** to enter PASS CODE SCREEN in USER MENU

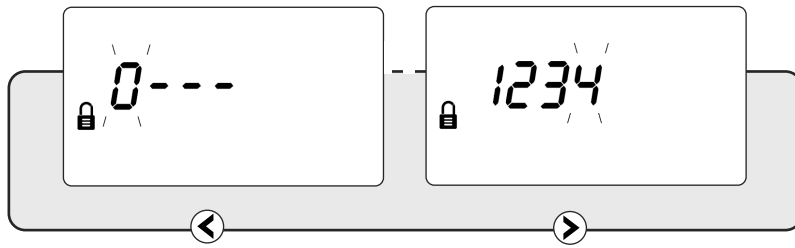

Default Pass Code: 1 2 3 4

- ▲** **▼** Change digit
- ◀** **▶** Move between digits
- ✓** Accept

- An incorrect Pass Code will return the display to the Pass Code entry screen
- Three incorrect attempts will lock access for three minutes

8. Finding Receivers

- Perform 'Find' during initial installation, or when adding or removing Receivers

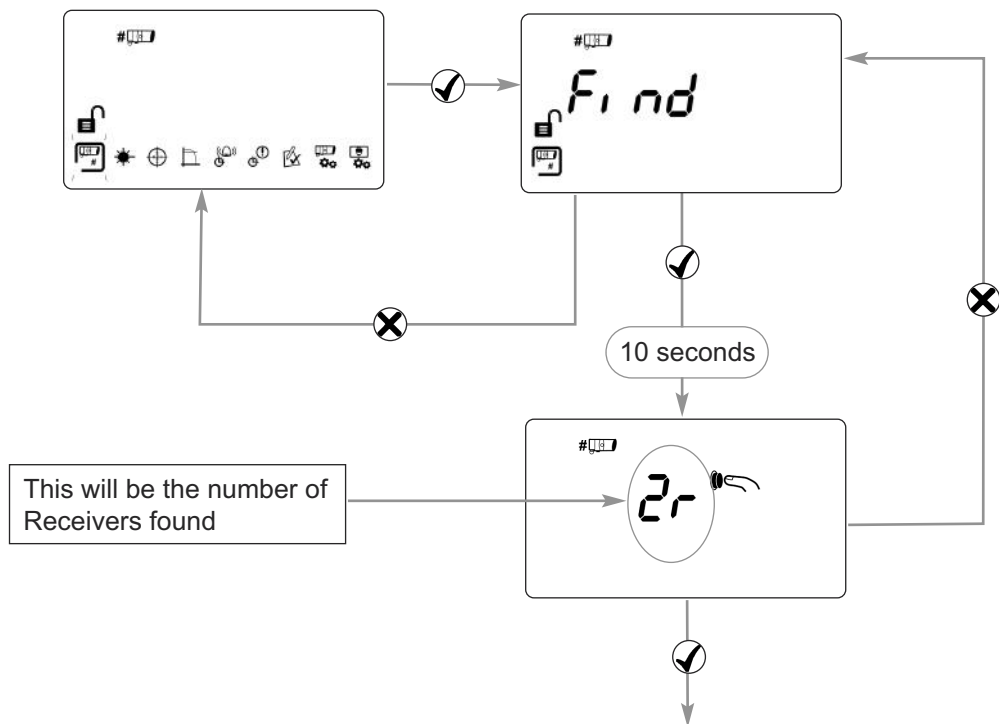

- Press **✓** to enable 'Found' Receivers
- Any unused Receiver channels are switched off
- Press **X** to re-scan if the number is incorrect

9. Select Receiver to be Accessed

- All Receivers need to be aligned separately
- Steps 8 and 9 explain how to align individual Receivers

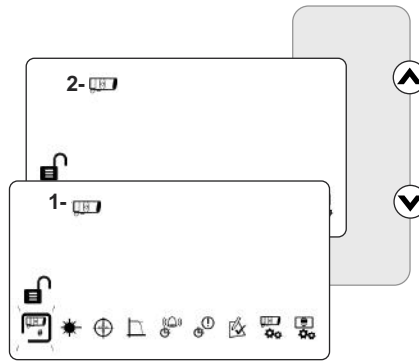

10. LASER Targeting

- The LASER in the Receiver head is used to align the Receiver with the Transmitter.
- The LASER can be activated using the LASER icon in the ENGINEERING MENU as shown below.
- Move the LASER as close to the Transmitter as possible, by moving the Receiver's bracket
- The system will signal Fault while in this mode

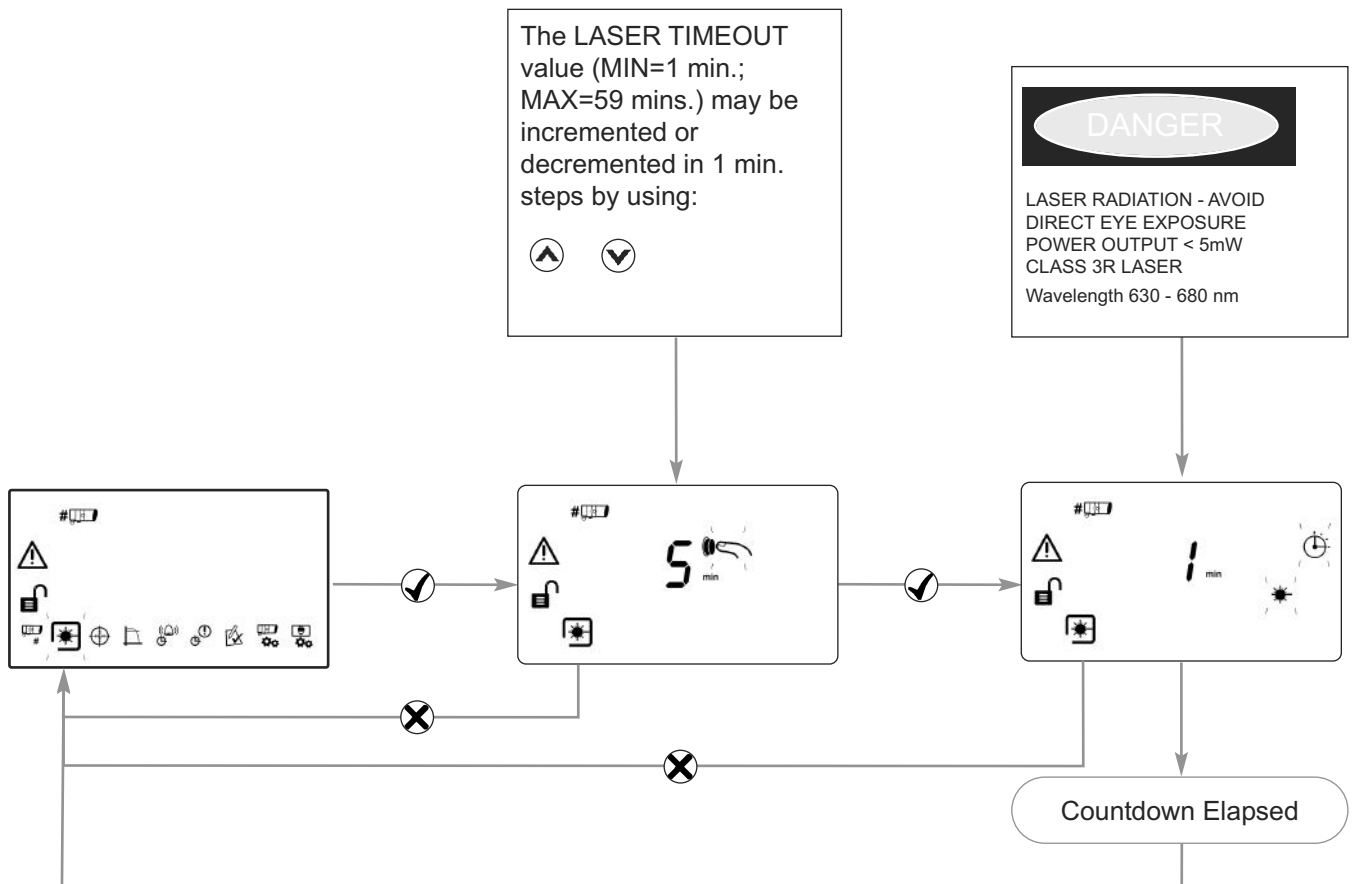

If it is not possible to see the LASER because of the installation environment (for example, if there is high ambient light) then align the Receiver by eye so that it is pointing at the Transmitter.

11. Alignment

In Alignment Mode you are centring the Transmitter beam onto the Receiver and the system is adjusting its power for optimum signal.

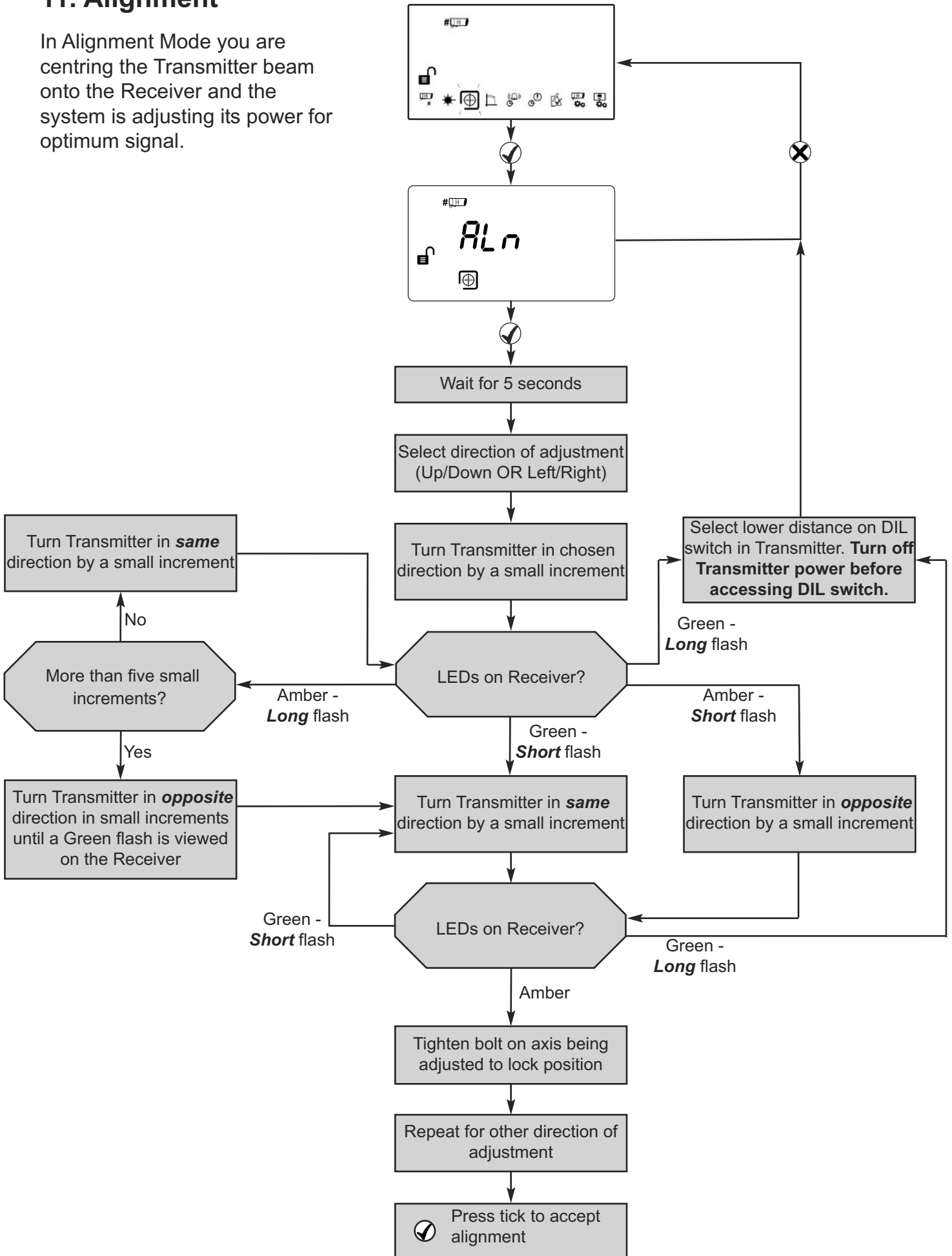

Visual representation of flowchart:

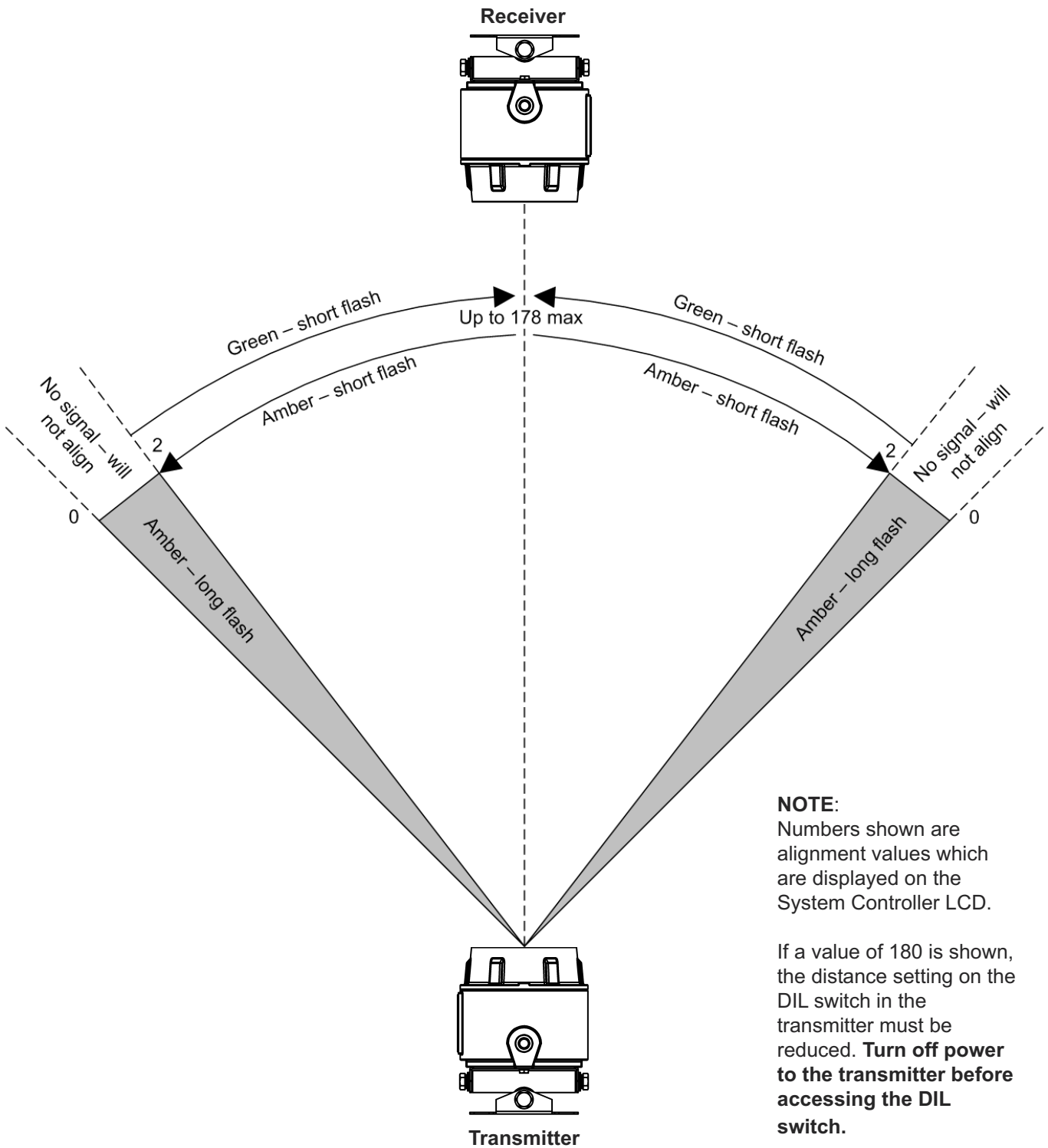

12. Manual Fire and Fault Tests

After installation or cleaning, it is recommended that a Manual Fire and Fault test is performed:

Fire Test: Slowly half-cover the Receiver. The Controller will indicate Fire after the Fire Delay Time.

Uncover the Receiver. The Controller will return to Normal state after approximately 5 seconds.

Fault Test: Completely cover the Receiver taking less than 2 seconds to do so. The Controller will indicate Fault after the Fault Delay time.

Uncover the Receiver. The Controller will return to Normal state after approximately 5 seconds.

13. Remote Fire Test

The Remote Fire Test allows the user to perform a Fire Test from the System Controller.

The Remote Fire Test is acceptable for Fire Authority Acceptance and Routine Maintenance per UL 268-5.

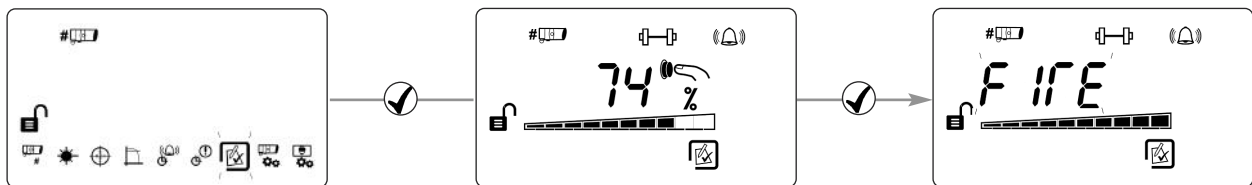

Receiver Fire LED Test

The Receiver will signal 'Fire', the System Controller will stay Normal.

Press **X** to exit without performing the test.

Relay / Controller Wiring Test

The System Controller signals 'Fire' to the Fire Control Panel. Press **✓** or **X** to exit.

14. Fire Threshold

This setting is the threshold at which the Receiver will detect a fire. Default factory setting=35%. (Set for each Receiver).

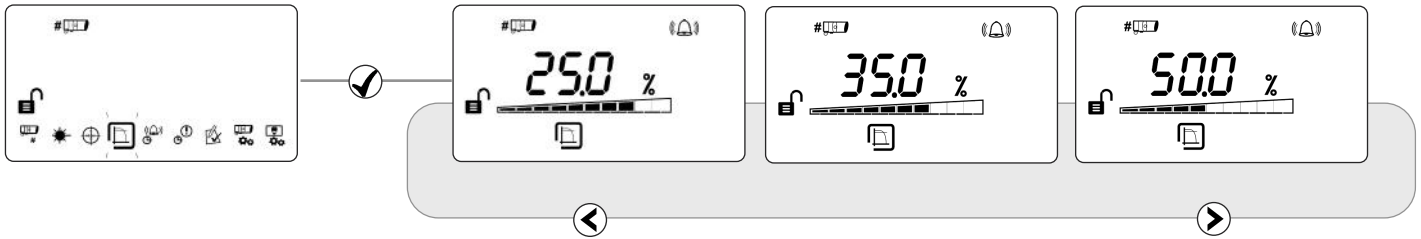

- Sensitivity can be adjusted in 1% steps by pressing up or down keys
- Press ✓ to accept setting

UL268 Fire Threshold Ranges:

Distance between Transmitter and Receiver	Fire Threshold Range
5 - 10m (16.4 - 32.8 ft)	25%
10 - 20m (32.8 - 65.6 ft)	25 - 30%
20 - 40m (65.6 - 131.2 ft)	25 - 45%
40 - 60m (131.2 - 196.8 ft)	35 - 60%
60 - 80m (196.8 - 262.5 ft)	45 - 60%
80 - 100m (262.5 - 328.1 ft)	55 - 60%
100 - 120m (328.1 - 393.7 ft)	60 %

EN Approved Sensitivity Ranges:

Complies with EN54-12 for sensitivity levels between 25% and 35%, with a maximum delay to fire of 20 seconds

15. Delay To Fire

This setting is the delay the System Controller uses before signalling a FIRE condition to the Fire Control Panel. Default factory setting=10 seconds.

(Set for each Receiver).

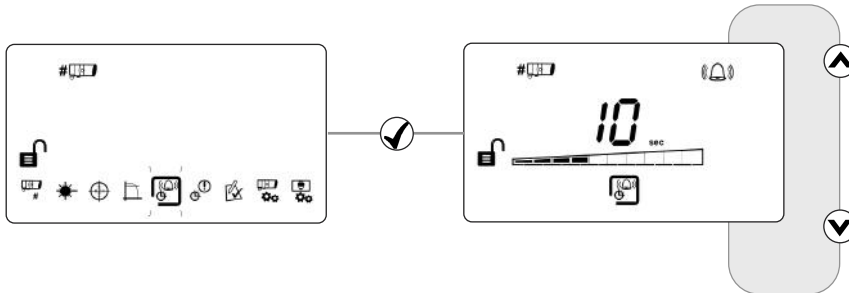

16. Delay To Fault

This setting is the delay the System Controller uses before signalling a FAULT condition to the Fire Control Panel. Default factory setting=10 seconds.

(Set for each Receiver).

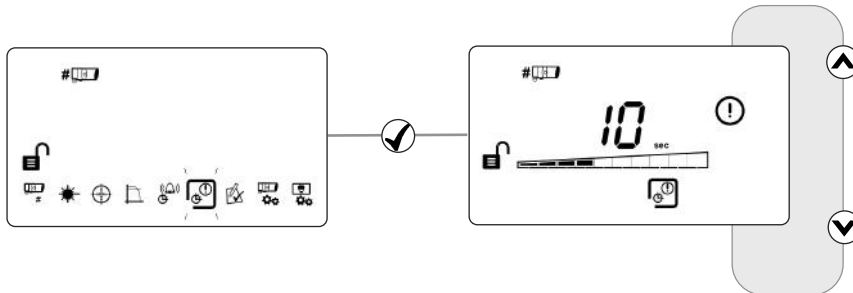

17. Latching/Non-Latching Mode

In Latching Mode the system will stay in Fire condition after the fire clears. In Non-Latching Mode the system will automatically return to normal condition after the fire clears

Default factory setting=Non-Latching (Set for each Receiver).

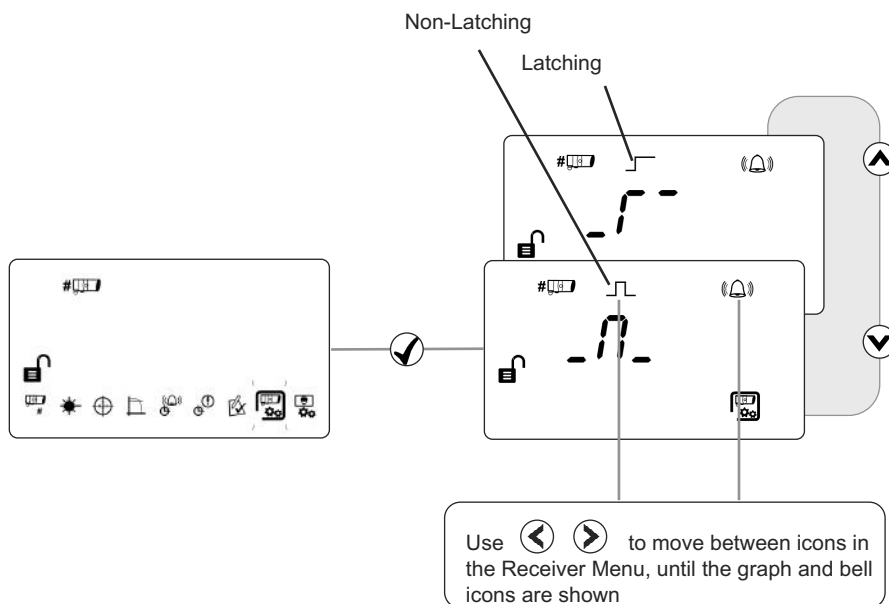

To clear a latched fire, apply 5-40V to the External Reset terminal, enter the passcode, or power cycle for 20s.

18. Maintenance

The system will automatically compensate for dust build-up by changing the Compensation Level. However, it is recommended that the Receiver lenses are cleaned periodically with a soft lint-free cloth.

The system should be isolated from the Fire Control Panel before cleaning takes place. After cleaning, verify that the system is operating normally by following the Alignment procedure and the Fire and Fault Tests described in this User Guide.

The Ex d Optical Beam Smoke Detector comes with a 5 year warranty as standard. With continued servicing and maintenance, the lifetime of the beam can exceed 10 years.

19. Troubleshooting

E-00	AIM not recognised	Refer to manufacturer for further technical assistance
E-01	Receiver Communications Fault	Check wiring between Controller and Receiver
E-02	'Find' not successfully executed	Follow 'Find' process
E-03	Compensation limit reached	Clean and re-align system
E-04	Receiver missed too many readings, or lost synchronization with the Transmitter	Ensure clear line of sight from Transmitter to Receiver
E-05	Receiver is not aligned	Follow alignment procedure
E-06	Rapid Obscuration Fault	Ensure clear line of sight from Transmitter to Receiver
E-07	Signal High Fault	Ensure there is no stray light from another source
E-15	Signal too low at end of alignment	Ensure clear line of sight from Transmitter to Receiver. Ensure alignment of Transmitter AND Receiver. Do not exit whilst alignment status LEDs are still flashing
E-16	Signal too high at end of alignment	Follow alignment procedure again. Do not exit whilst alignment status LEDs are still flashing
E-18	Short circuit detected on communications between Controller and Receiver	Check wiring between Controller and Receiver
E-19	IR signal integrity fault	Check there are no strong sources of light near the Receiver, or direct sunlight
E-20	Ambient light fault	Check there are no strong sources of light near the Receiver, or direct sunlight
E-21	Power too low fault	Check power supply to Controller

20. Technical Specifications

Parameter	Value
Operating Distance between Transmitter and Receiver	10 to 100m
Operating Voltage	12 to 36V DC +/- 10%
Operating Current - Controller (with 1 or 2 Receivers)	14mA
Operating Current - Transmitter	8mA
Power Down Reset Time	>20 seconds
Fire and Fault Relay Contacts	VFCO 2A@ 30 Volts DC, resistive
Maximum Cable Length (Controller to Receiver)	100m
Operating Temperature	-10°C to +55°C (non-condensing) - EN -20°C to +55°C (non-condensing) - UL
Storage Temperature	-40°C to +85°C (non-condensing)
Optical Wavelength	850nm
Receiver Tolerance to Beam Misalignment at 25% sensitivity	± 2.5°
Transmitter Tolerance to Beam Misalignment at 25% sensitivity	± 0.7°
Fire Threshold Range	0.45 - 3.98 dB 10 - 60%
Delays to Fire and Fault	2-30s, individually selectable
Rapid Obscuration Fault Threshold	85%
LED Indications - Control Unit:	Red = Fire (one for each Receiver) Amber = Fault (one for each Receiver) Green = System OK
Receiver:	Green and Amber indication LEDs for single-person alignment
IP Rating	IP54 - Controller IP66 - Receiver/Transmitter
Relative Humidity	93% (non-condensing)
Housing Construction - Controller: Transmitter/Receiver: <i>Sealing Ring</i> Bracket:	UL94 V0 PC Copper Free Aluminium Alloy LM25, red OR 316 Stainless Steel, natural EPDM 70 Steel, red
Cable Gland Entries	3 x 20mm

Dimensions	Width, mm (in)	Height, mm (in)	Depth, mm (in)	Weight, kg (lb)
Controller Unit	203 (8.0)	124 (4.9)	73.5 (2.9)	0.606 (1.3)
Transmitter & Receiver	149 (5.9)	172 (6.8)	190 (7.5)	3.7 (8.2) inc. brackets

