

TR-UF45-E-IN Fixed Dome Plate Mount

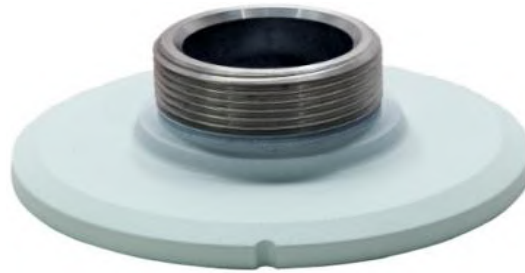

Specifications

Bracket	TR-UF45-E-IN
Application	Indoor, wall or pendant installation for IPC323 series
Dimensions	Φ149mmx44mm(Φ5.9" x1.7")
Weight	0.2kg(0.44lb)
Material	Aluminum alloy

Dimensions

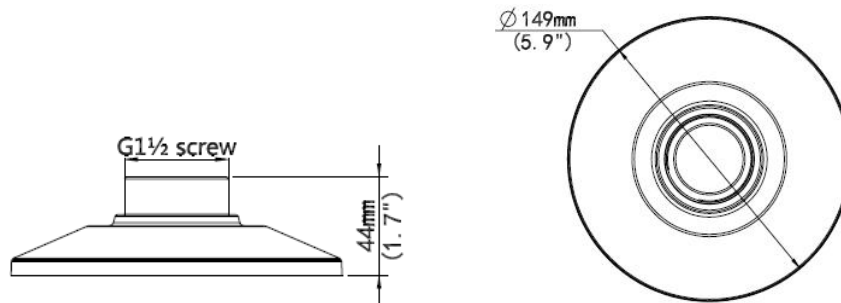

Zhejiang Uniview Technologies Co.,Ltd.

South Tower, Building 10, Wanlun Science Park, 88 Jiangling Road, Hangzhou, P.R.China 310051

Email: overseasbusiness@uniview.com; globalsupport@uniview.com

<http://www.uniview.com>

©2015 Zhejiang Uniview Technologies Co.,Ltd. All rights reserved.

*Product specifications and availability are subject to change without notice.